

THORENS TD 104

SERVICE TD 105



THORENS

Service Manual

TD 104 / TD 105

Turntables

Table of Contents	Page
GENERAL INSTRUCTIONS	1
MECHANICAL COMPONENTS	2
ELECTRONIC COMPONENTS	7
EXPLODED VIEWS	19
LIST OF SPARE PARTS	23

GENERAL INSTRUCTIONS

To prevent contamination of the turntable bearing, do not remove the inner turntable platter except for servicing components located underneath or for lifting the suspended chassis (7604001/7605001). The chassis is to be lifted perpendicularly from the base after the arresting bolt (6845066) has been removed. The cables between the chassis and the base can be drawn out to full length by removing the rubber rollers.

MECHANICAL COMPONENTS

1. Platter Bearing

a) *Lubrication.* Under normal conditions, the lubricant of the platter bearing requires replenishment only after several thousand hours of operation. Use only an appropriate sinter-bearing oil such as Mobil DTE Heavy Medium (available from THORENS).

b) *Bearing Noises.* In the event of detectable noise or increased rumble, first clean and relubricate the bearing. If the disturbances persist, replace the bearing sleeve (4252015), the support disk (6605030), and the guide sleeve (6605031), which constitute the bearing assembly, as follows. Remove the turntable platter, unscrew the arresting bolt, and remove the contact leaf (6605033) next to the bearing assembly by unscrewing the Phillips-head screw. Lift the chassis out of the base. Press upon the white insert piece (6605024) underneath the bearing well to force the bearing components out of the upper side of the chassis. When replacing the bearing assembly, press all components firmly into place to prevent leakage. Lubricate the assembly.

2. Chassis Suspension Module

The suspended chassis must be free to move at least ± 2 mm horizontally and vertically. Should the motion of the chassis be restricted by a defective pressure spring, pull off the corresponding chassis suspension module (7605018) from the pin in the base and replace the entire module.

3. Height Adjustment of the Lift Platform

Slide the mounting gauge (6880019) over the tone arm head. Raise the tone arm with the lift lever. Place a phonograph record on the turntable platter. After loosening the Allen screw, adjust the height of the lift platform (7605011) so that the underside of the gauge just rests on the record. The height of the stylus tip above the record now lies between 5.5 and 6 mm.

4. Lift Mechanism

If the raising and lowering times have become excessively long because of contamination of the lift mechanism, the lift shaft and guide are to be serviced as follows. Remove the turntable platter, unscrew the arresting bolt, and lift the chassis out of the base. Remove the lift platform (7605011), the transmission bar (TD 105 – 6605015), and the lift bar (6605065). After the

7605011

6880019

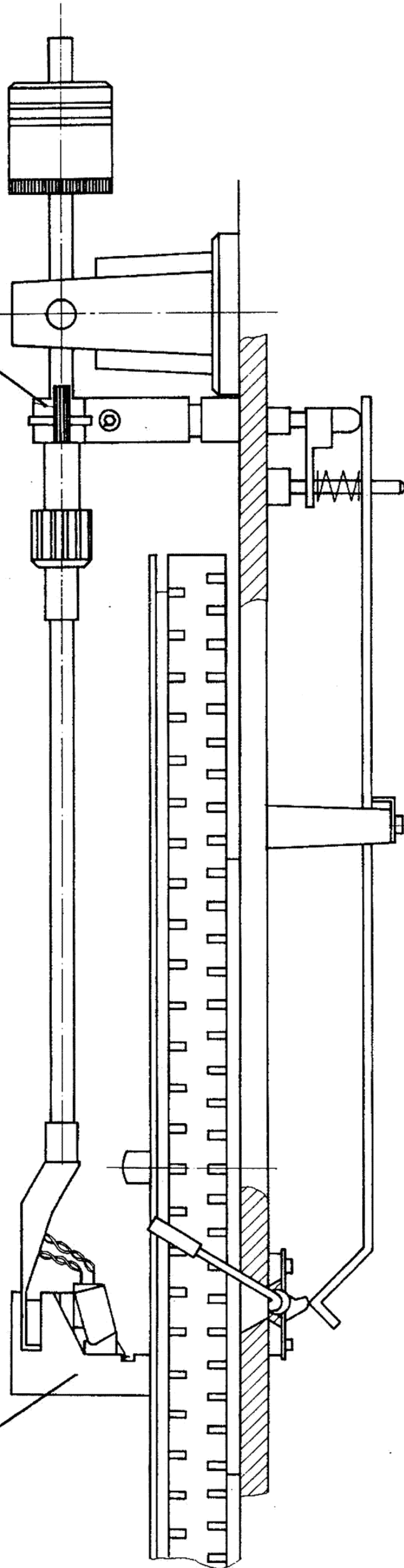

clip washer has been removed, the lift rider (7605009/7605010) can be pulled out from the underside of the chassis. Clean the shaft and guide and apply Silicon AK 100 000 (5310017) damping fluid before reassembly.

The automatic lift function of the TD 105 is treated in Section 5a).

5. Automatic Tone Arm Return Mechanism (TD 105)

Before performing the adjustment procedures in this section, verify that the lift platform is properly adjusted according to Section 3.

a) *Height Adjustment of the Tone Arm for Automatic Operation.*

Lower the tone arm with the lift lever. After removing the turntable platter, turn the curve disk (7605002) underneath by hand in a counterclockwise direction until the tone arm is again raised and the return function begins. Screw out the arresting bolt. Insert the turntable platter back into the bearing and place a phonograph record on the platter. Slide the mounting gauge (6880019) over the tone arm head and position the arm over the record. Lift the chassis out of the base. After loosening the locknut, turn the curve finger (6605064) which extends into the curve disk until the underside of the gauge just rests on the record. Retighten the locknut.

In older units, if the return function begins before the tone arm is fully raised, replace the curve disk with the newer, redesigned version.

b) *Adjustment of the Return Rider.* After the height of the tone arm has been adjusted, check the position of the auto-stop shutter as described in Section 9e). Then loosen the painted locknut (6872012) on the transmission bar in the vicinity of the tone arm. Turn the guide sleeve (6605016) until a separation of 1 – 2 mm is present between the clip washer on the return rider (6605017) and the sleeve end. Retighten the locknut.

c) *Correction of Cycling Defects.* Should the tone arm and platter come to rest before the return cycle has been completed, check whether the three contact pairs (assembly 4186017) are closing during the cycle interval:

upper two pairs — audio muting
lower pair — motor

If closing does not occur, change the position of the contact assembly or adjust the contact pair remaining open.

The magnet (4223027) must be positioned with the two mounting screws so that the metal lever on the curve disk engages the teeth on the inner platter. If the magnet does not pull in, see Section 9f).

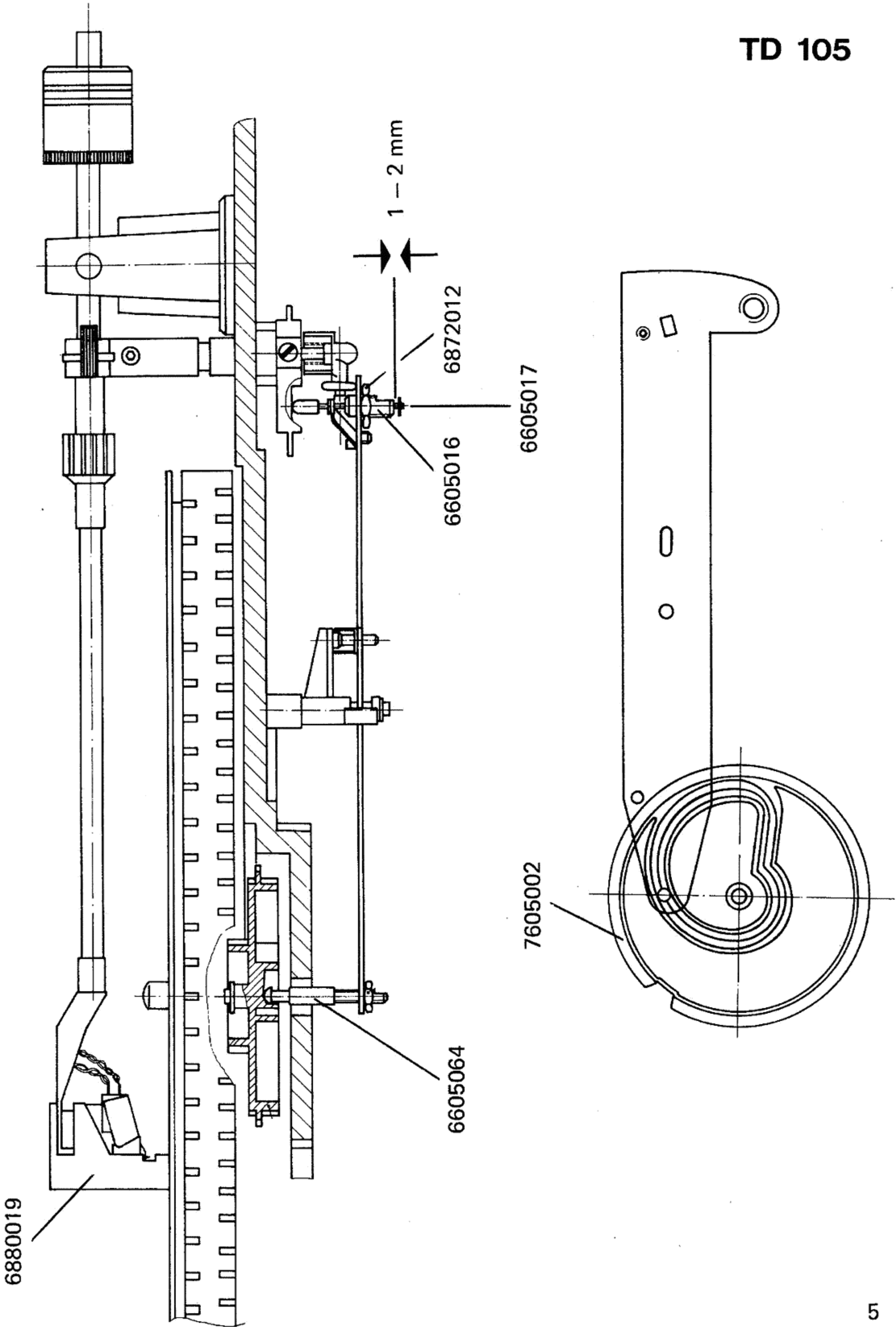

6. TP 22 Tone Arm Bearing Assembly

a) Checking the Signal Leads. Should the tone arm not move freely, the signal leads should first be checked for possible binding. Remove the turntable platter, unscrew the arresting bolt, lift the chassis, remove the transmission bar (TD 105 – 6605015), unscrew the antiskating lever (6605042 – do not stretch the spring!), and remove the shielding cover (6605013) by unscrewing the two screws.

When remounting the antiskating lever, turn the antiskating knob to "0" and position the lever at the end of its travel range such that the spring anchor point lies above the rotational center of the bearing assembly.

b) Replacement. If excessive friction is due to a defective bearing, or if the bearing assembly is damaged, the following replacement procedure is to be employed. Perform the steps in part a) above, and unsolder the signal leads. Remove the shielding angle (6605014), the auto-stop shutter (6605054), and the auto-stop board (TD 105 – 7605005). Remove the mounting screws under the bearing assembly and lift the assembly out of the chassis from above.

After installing the replacement bearing assembly (9885000), adjust the position of the auto-stop shutter in the TD 105 according to Section 9e), mount the antiskating lever according to part a), and check the adjustment of the return rider (TD 105) according to Section 5b). With reinstallation complete, verify electrical continuity between the external ground wire (4240015) and the shielding cover as well as the blank aluminum parts of the tone arm using an ohmmeter.

7. TX 105 Dust Cover

The tension of the hinge springs (4320049) can be adjusted by changing the position of the anchoring screws underneath the base. The fine adjustment is performed with the hinge screws, accessible through the side holes.

ELECTRONIC COMPONENTS

8. Circuit Description

a) *Power Supply.* The power supply (D 102 – D 105, etc.) is fed from the AC mains adapter to deliver three DC voltages:

- approximately + 18 V
- "+10 V" (in reality $V_{D106} - V_{T101} = +10\text{ V} - 0.7\text{ V} = +9.3\text{ V}$)
- +4.7 V (produced by D 106 and Z 102-2).

b) *Speed Selection Circuitry.* The +4.7 V supply constitutes the reference voltage source for the determination of the turntable speed. A positive voltage is produced at one of the outputs of the MOS-NAND circuit Z 201 for the speed selection. D 117 or D 116 is turned on by the positive signal on output 3 or 10, thus applying the reference voltage to the corresponding resistive network (33 or 45 RPM). T 109 and T 110 function as current sources for the indicator LED's D 210 and D 212. A positive voltage on output 4 of Z 201 is applied through D 112 and R 133a directly to pin 13 (the negative input) of Z 102-1 to stop the motor. Closing one of the speed selector keys forces the corresponding input (1, 5 or 8) of Z 201 to 0 V. The resulting positive output voltage on pin 3, 4 or 10 is fed to the other two inputs through D 201 – D 206 to prevent erroneous switching. When power is applied to the turntable, the STOP function is initially actuated through C 201. Both other inputs are connected to +10 V through R 210 and R 212 (in earlier units D 207 and D 209).

c) *Motor Control Circuitry.* The DC motor (M) is fed from Z 102-1 through T 104. The speed is determined basically by the reference voltage on pin 13. The signal from the tachometer (G) is amplitude-limited by Z 101-1 and converted into switching pulses by Z 101-2. The pulses bring T 103 briefly into conduction once per tachometer period. Z 101-4 is reset at the beginning of each tachometer period by a pulse from Z 101-2/Z 101-3 and then generates a sawtooth voltage during that tachometer period. At the end of the period, the amplitude of the sawtooth voltage is transferred to C 109 by the brief conduction of T 103. A speed deviation will cause the tachometer period to change, producing a corresponding voltage change on C 109; the speed of the motor will thus be altered to correct for the deviation. D 101a provides for optimum platter acceleration by insuring that C 109 is immediately charged during run-up.

d) *Stroboscope.* When either 33 or 45 RPM operation is initiated by Z 201, T 105 and T 106 are brought into conduction. The two stroboscope LED's are pulsed on and off in synchronization with the AC mains frequency, delivered from the secondary voltage at connection 1/26.

e) Auto-Stop (TD 105). During record play, the optical path between the light-emitting diode D 301 and the photodiode D 302 is interrupted by the rotating shutter (6605054). When the path is opened at the end of the record or in the region of the tone arm rest, the luminous intensity of D 301 and the angular position of the shutter determine the resistance of D 302. The setting of R 149 determines the magnitude of the resulting voltage increase at the positive input (10) of Z 102-4, which functions as a differentiator owing to R 153 and the parallel combination of C 118/C 119. When the stylus travels into the lead-out groove, the input voltage rapidly increases. As a result, the output voltage of the differentiator rises sufficiently to bring T 108 into conduction and thus switch Z 201 to STOP. When the unit is turned on, C 119 is first charged to about half the supply voltage because of the capacitive dividing action with C 118. The resulting high voltage at the negative input (9) blocks the differentiator, preventing the generation of spurious stopping pulses due to turn-on disturbances. C 119 then discharges until the normal operating point is reached. R 152, R 156, C 120, and C 121 prevent the circuit from being triggered by noise pulses.

f) Tone Arm Return (TD 105). The monostable multivibrator Z 102-3 is triggered from the STOP output of Z 201 and determines the holding time of the magnet RS, which initiates the tone arm return function. The magnet closes the three contact pairs, two of which short the audio signal leads during the return cycle. R 133 and D 111 are grounded through the third contact pair, dividing the STOP output voltage so that the motor runs at approximately 33 RPM (platter speed) while returning the arm. C 116 prevents triggering of Z 102-3 when power is applied to the turntable.

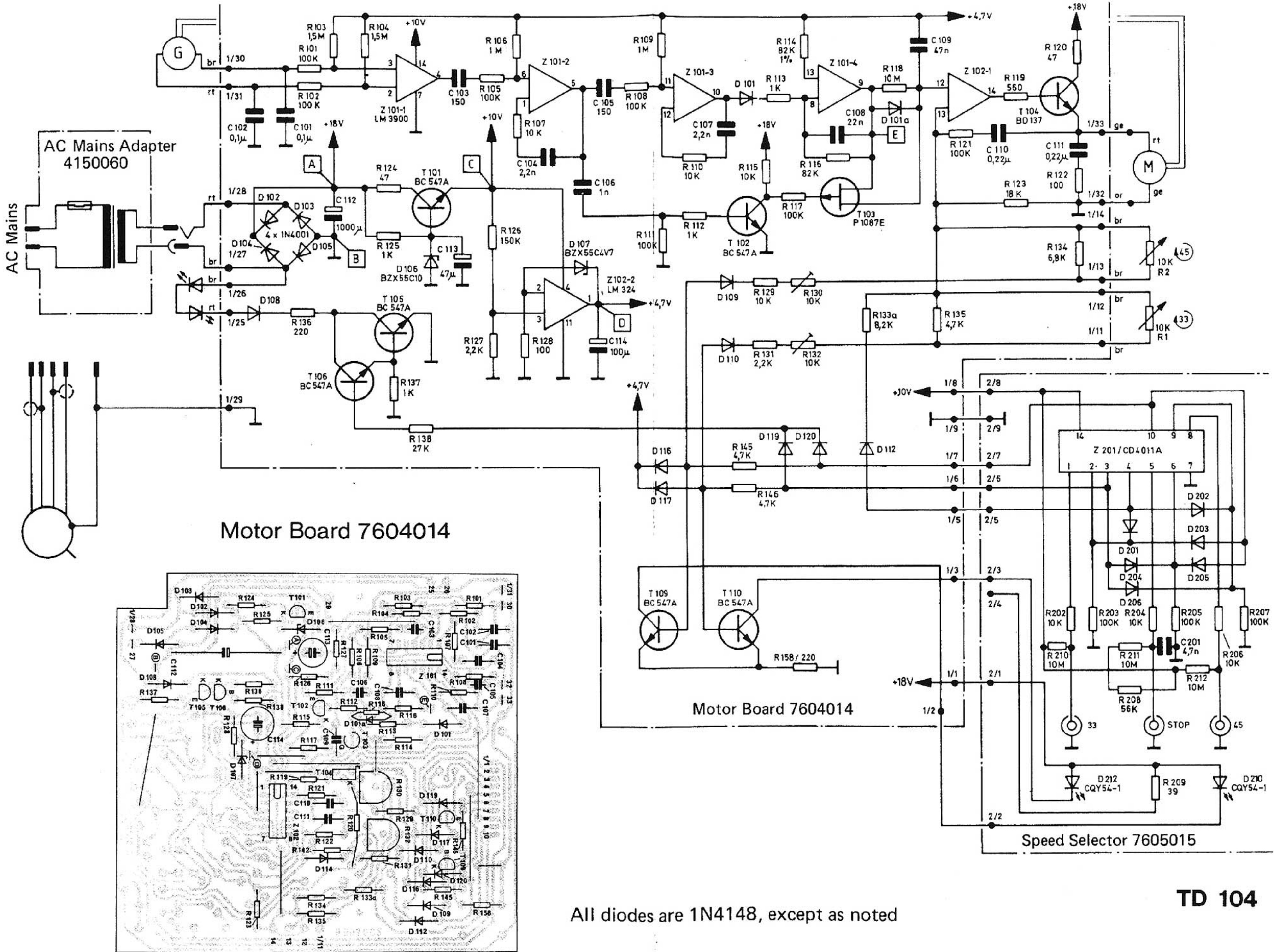

Motor Board 7604014

Motor Board 7604014

Speed Selector 7605015

All diodes are 1N4148, except as noted

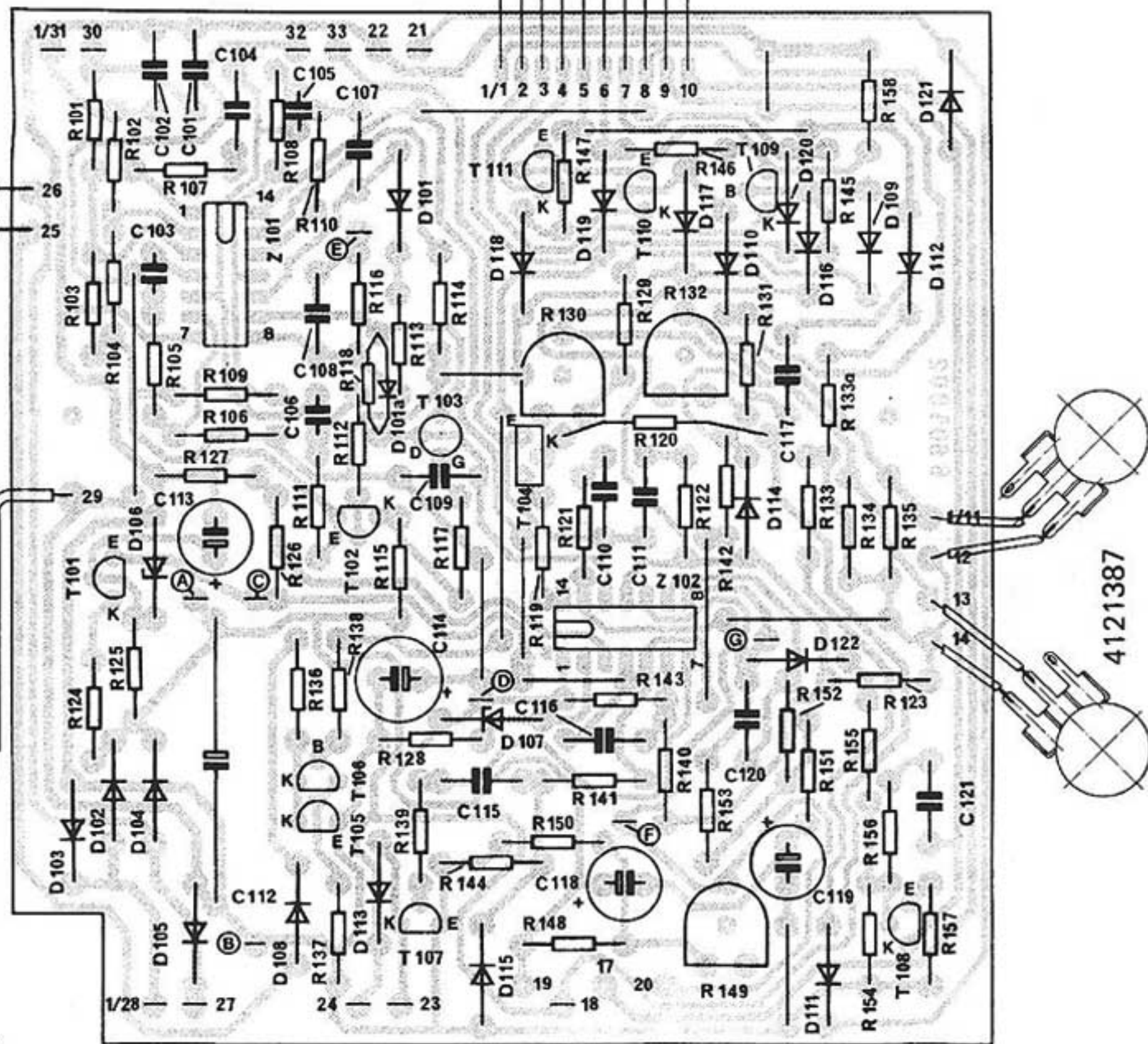
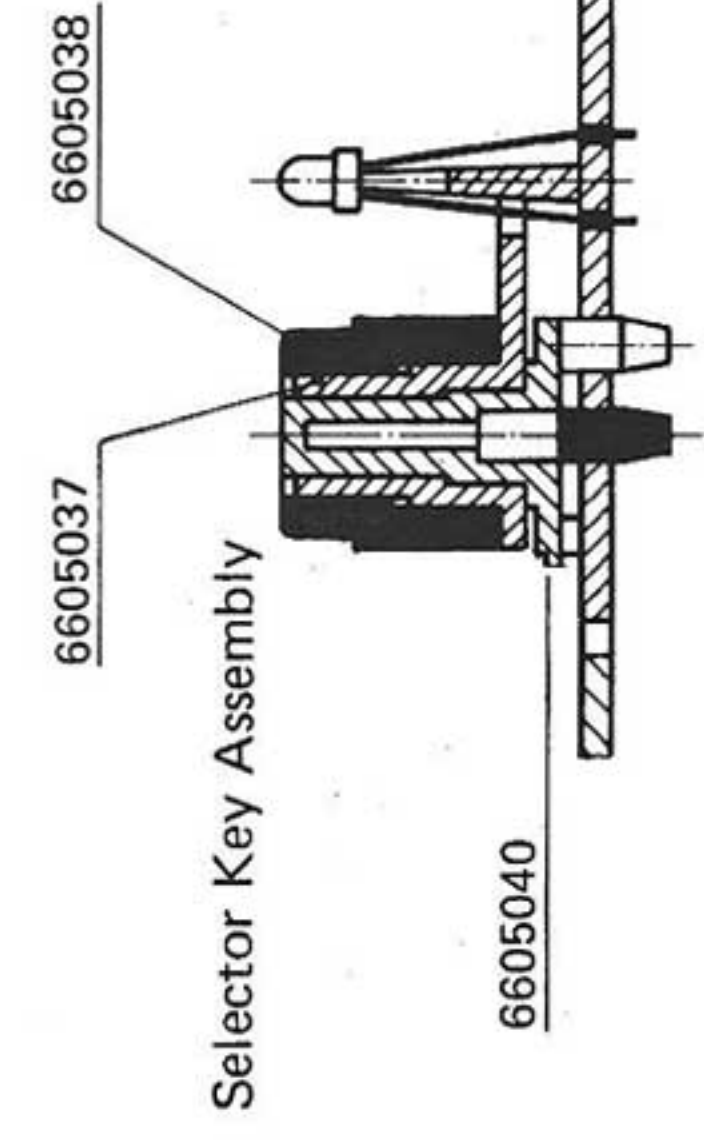
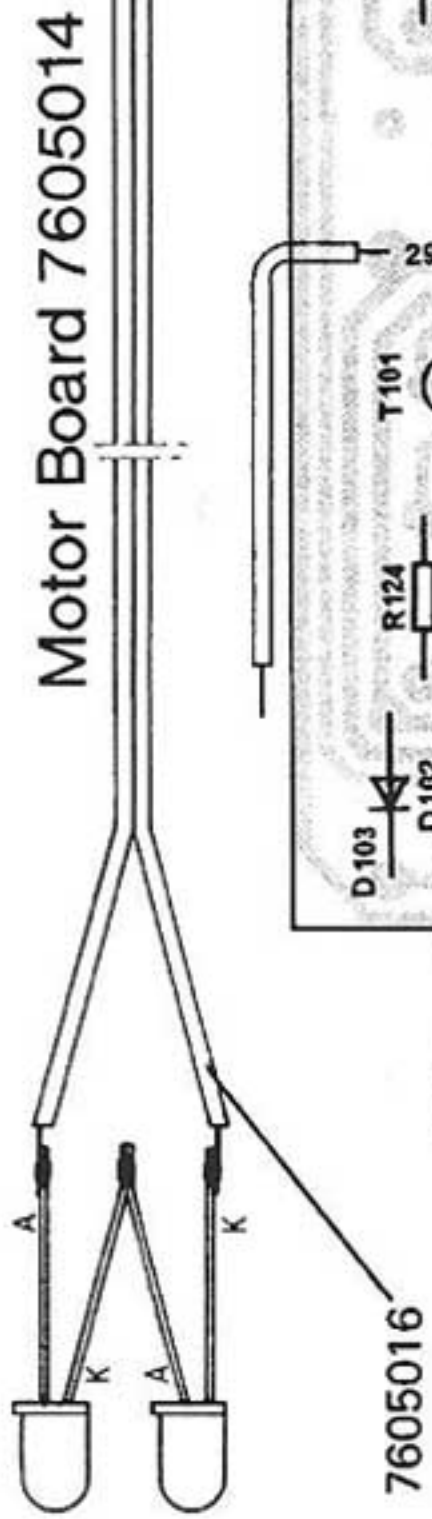

Speed Selector 7605015 (TD 104/105)

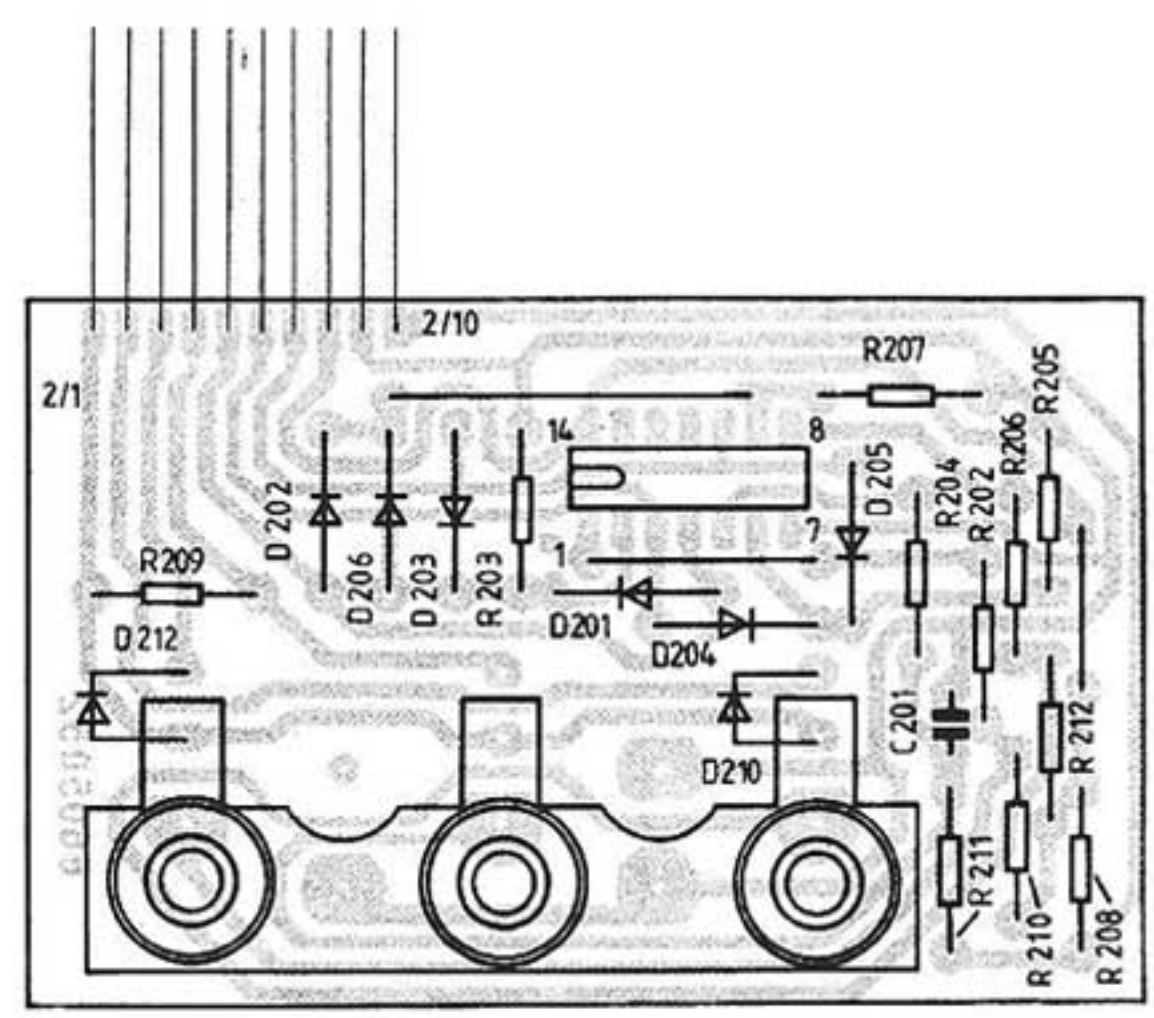

Auto-Stop Board 7605005

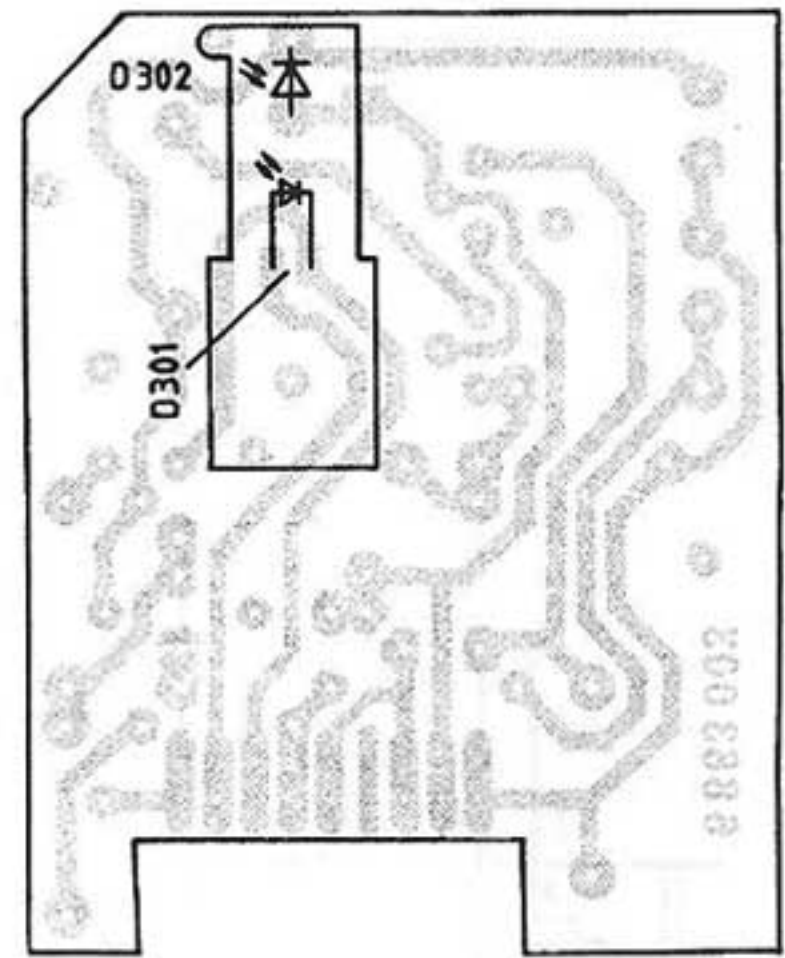

Auto-Stop Diode Assembly

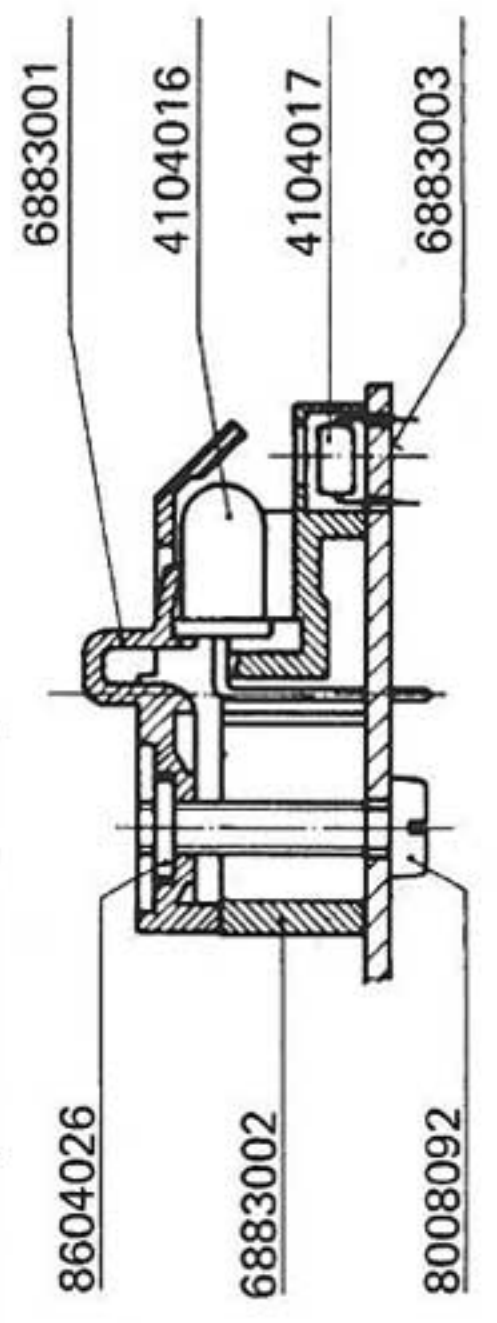

TD 105

9. Operating Voltage Measurements and Functional Checks

Remove the turntable platter, unscrew the arresting bolt, and lift the chassis out of the base. All voltages specified below are referred to 0 V (test point B), except as otherwise noted.

a) Power Supply

Secondary voltage of AC mains adapter $\left\{ \begin{array}{l} \leq 20 \text{ VAC for } 0 \text{ mA load current} \\ \geq 10 \text{ VAC for } 300 \text{ mA load current} \end{array} \right.$

Under no circumstances attempt to open the mains adapter!

Test point A – STOP app. +20 VDC, 0.2 VAC dependent on mains voltage

Test point A – 33 & 45 app. +18 VDC, 0.4 VAC dependent on mains voltage

Test point C +9.3 VDC \pm 5%

Test point D +4.7 VDC \pm 5%

b) *Speed Selection Circuitry.* When the unit is turned on, the motor must remain stopped and the two LED's (33 and 45) extinguished. Each LED illuminates when the corresponding speed is selected. Clean the selector keys with mineral spirits if faulty switching occurs.

To test the circuitry, remove the shielding cap (7605023) underneath the selector area. All voltages specified are DC values.

Connection	STOP	33	45
2/1	app. +20 V	app. +18 V	app. +18 V
2/2	app. +18.5 V	app. +17 V	app. +16.5 V
2/3	app. +19 V	app. +16.5 V	app. +17 V
2/4 (TD 105)	app. +19 V	app. +18 V	app. +18 V
2/5	+9.0 V \pm 5%	app. 0 V	0 V
2/6	app. 0 V	+9.0 V \pm 5%	0 V
2/7	app. 0 V	app. 0 V	+9.0 V \pm 5%
2/8	+9.3 V \pm 5%	+9.3 V \pm 5%	+9.3 V \pm 5%
2/9	0 V	0 V	0 V
2/10	+9.3 V \pm 5%	+9.3 V \pm 5%	+9.3 V \pm 5%

To prevent faulty switching in older units, replace diodes D 207, D 208 and D 209 with 10 MOhm resistors (R 210, R 211, R 212), and change C 201 to 4700 pF.

c) *Motor Control Circuitry.* All measurements are valid for 33 RPM without mounted turntable platter.

	DC Voltage	AC Voltage (T = app. 2 ms)
Conn. 1/30	app. +0.5 V	100 mV p-p, sine wave
Conn. 1/31	app. +0.5 V	100 mV p-p, sine wave
Z 101-1 (4)	app. +5 V	9 V p-p, square wave
Z 101-2 (6)	app. +0.5 V	0.5 V p-p, negative pulses (*)
Z 101-2 (1)	app. -0.05 V	1 V p-p, positive pulses (*)
Z 101-2 (5)	app. +0.75 V	9 V p-p, positive pulses (*)
Z 101-3 (11)	app. +0.5 V	0.7 V p-p, negative pulses (*)
Z 101-3 (12)	app. -0.05 V	1 V p-p, positive pulses (*)
Z 101-3 (10)	app. +0.75 V	9 V p-p, positive pulses (*)
Z 101-4 (13)	app. +0.5 V	60 mV p-p, positive pulses (*)
Z 101-4 (8)	app. +0.5 V	0.4 V p-p, positive pulses (*)
Z 101-4 (9)	app. +1.8 V	3 V p-p, sawtooth (width = 2 ms)
T 102-V _B	app. -0.3 V	6 V p-p, negative spikes
T 102-V _C	app. +18 V	18 V p-p, negative pulses (**)
Z 102-1 (12)	app. +3 V	0.1 V p-p, ramp
Z 102-1 (13)	app. +3 V	20 mV p-p, ramp
Z 102-1 (14)	app. +2.1 V	0.1 V p-p, ramp
Conn. 1/33	app. +1.4 V (load dependent)	

(*): pulse width = 0.2 ms

(**): pulse width = 0.1 ms

The voltage drop on R 120 is approximately 0.7 VDC.

If the motor does not always start, check to see if D 101a (included in later units) is present in the circuit. The current consumption of the motor is about 16 mA when fed from an external 2 VDC source. Deviations from this figure are unimportant as long as specified performance is maintained. Replace a defective motor only as a complete assembly (7605012).

The speed range trimmers should be readjusted whenever the motor control circuitry has been repaired or the motor replaced. Turn R 1 and R 2 (fine speed adjustment knobs) to their mechanical middle points and adjust R 130 and R 132 to achieve a stationary stroboscope pattern at each speed.

d) Stroboscope

Test Point	STOP	33 or 45
T 106 V_E	0 V	app. +0.5 VDC
V_B	0 V	app. +1.2 VDC
V_C	app. +15 VDC	app. +0.5 VDC

e) Auto-Stop (TD 105)

If the shutter (6605054) is not in the middle of the slot of the diode assembly, loosen the screw, readjust the position, and tighten the screw.

Secure the tone arm in the rest. The voltage at test point F should lie at approximately +1 VDC; adjust with R 149 if necessary. Move the tone arm over the playing region. The voltage at point F decreases to about +0.5 V. The voltage at point G must be less than +1 V, and the collector voltage of T 108 lies at approximately +9.3 V. Start the motor by touching one of the selector keys. When the tone arm is held over the playing area for a few seconds and then moved to the lead-out groove region, the voltage on point G must rise to +8 V, the collector voltage of T 108 should fall to nearly 0 V, and the motor must stop.

If stopping occurs at the wrong point on the record, position the tone arm with the enclosed template to hold the stylus point 48 mm from the center of the platter. Loosen the shutter screw. Position the shutter in the middle of the slot of the diode assembly and rotate to the point where the voltage at test point G just rises to +8 V. Tighten the screw and test operation with a phonograph record.

After readjusting the shutter position, the return rider must be readjusted as described in Section 5b).

f) *Tone Arm Return (TD 105)*. During record play, the output voltage of Z 102-3 (pin 7) lies at 0 V and the collector voltage of T 107 at approximately +18 VDC. When the STOP mode is activated by the speed selector key or by the auto-stop circuit, the voltage on pin 7 must rise to about +9 V, the collector voltage decrease to nearly 0 V, and the magnet RS pull in for at least 0.3 seconds and then release. Replace the magnet (4223027) if it does not pull in. The motor must run until the contact which is closed by the magnet opens again.

10. Elimination of Hum Disturbances

If hum disturbances persist despite observance of the measures treated in the instruction manual, use an ohmmeter to check for a possible — incorrect — low-resistance path between the black grounding wire and the audio connectors. If electrical conduction be determined, repeat the test with the cartridge wand removed. A collar of insulating material between the tube and the head of the wand is intended for electrically separating the chassis ground system (black wire) from the audio ground in the turntable. Finally, check the shield connection of the pickup cartridge, referring to the manufacturer's specifications. The green wire in the head should be joined with the shield connection.

11. Equipping the Turntable with Low-Capacitance Cables

The capacitance of the audio cables influences the reproduction characteristics of the pickup cartridge at very high frequencies. The AF cable used in production units exhibits a capacitance of approx. 200 pF per channel and is 200 cm long. If the pickup cartridge employed requires a low termination capacitance, suitable low-capacitance cables can be supplied. However, since the capacitance of approx. 1 pF per cm of cable length is uniform, it is often more convenient to shorten the standard cable to lower the capacitance appropriately. In determining the total capacitance terminating the cartridge, the internal lead capacitance of 20 pF (TD 104) or 170 pF (TD 105) as well as the input capacitance of the phono preamplifier must be added to the cable capacitance.

TD 104

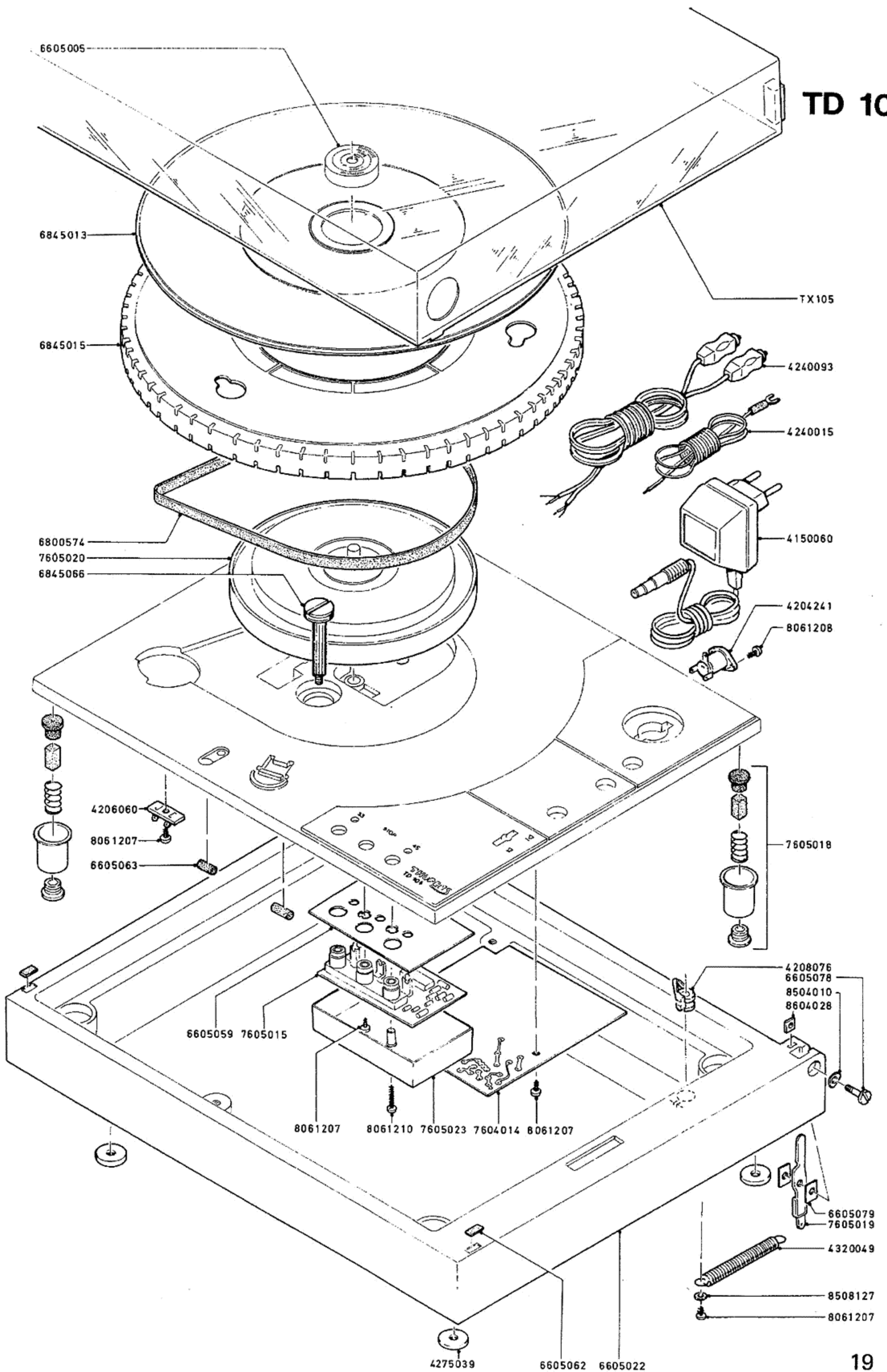

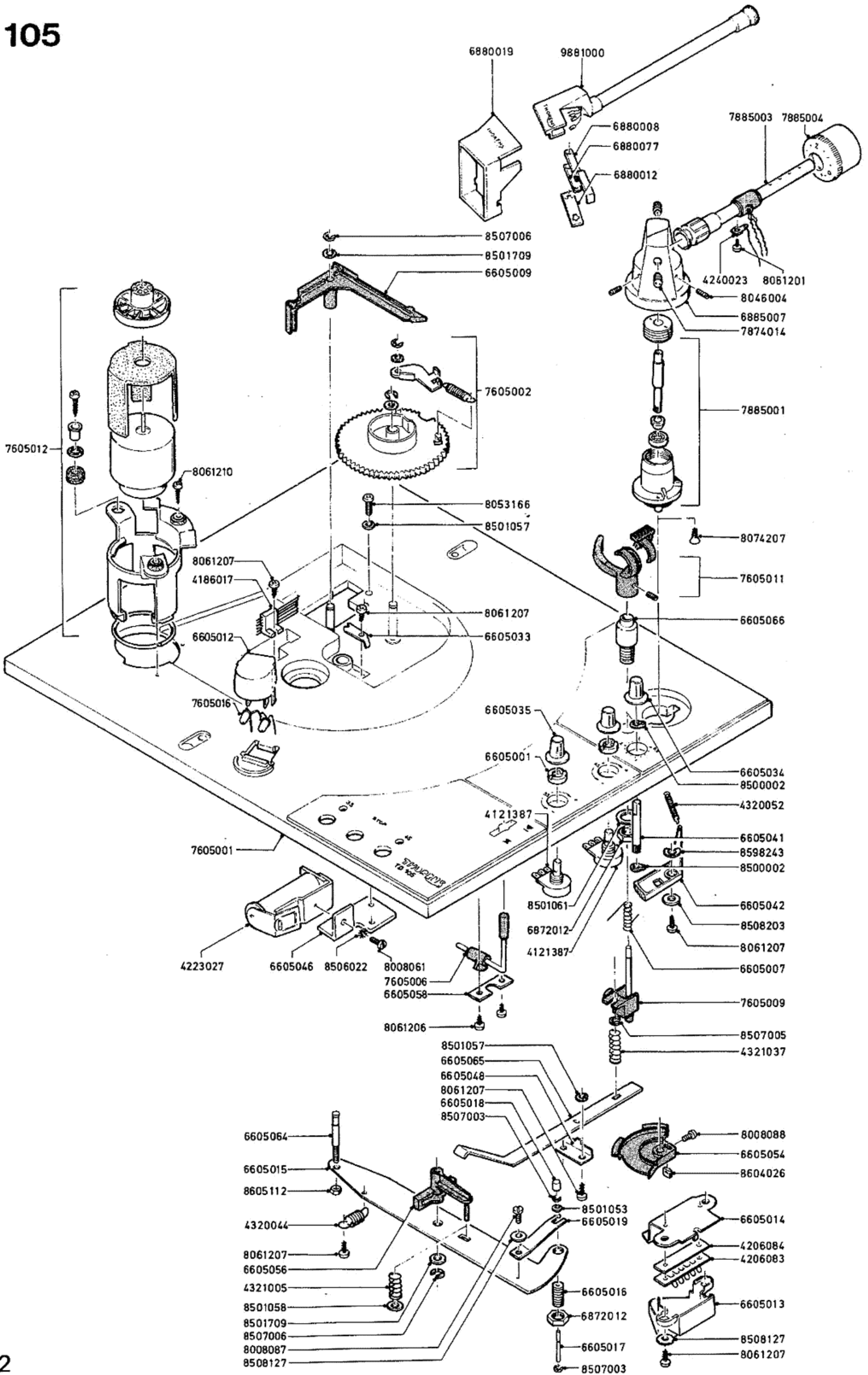

LIST OF SPARE PARTS

2003513	TX 105 Dust cover	6605037	Insulating body
4104016	LED – LD 271A	6605038	Outer contact
4104017	Photodiode BPW 34 E 7090	6605040	Inner contact
4121387	Potentiometer	6605041	Lifting shaft
4150060	AC mains adapter	6605042	Antiskating lever
4186017	Contact assembly	6605046	Magnet holder
4204241	Power socket	6605048	Holding piece
4206060	Terminal strip	6605054	Shutter
4206083	Miniature terminal strip	6605056	Pivot bearing
4206084	Covering strip	6605058	Holding spring
4208076	Grommet	6605059	Shielding plate
4223027	Magnet	6605062	Rubber bumper
4240015	Ground wire	6605063	Rubber roller
4240023	Ground lead	6605064	Curve finger
4240093	AF cable	6605065	Lift bar
4252015	Bearing sleeve	6605066	Lift guide
4275039	Felt washer	6605078	Hinge screw
4320044	Tension spring	6605079	Hinge washer
4320048	Tension spring	6800574	Rubber belt
4320049	Tension spring	6845013	Rubber mat
4320052	Tension spring	6845015	Outer platter
4321005	Pressure spring	6845066	Arresting bolt
4321037	Pressure spring	6872012	Hexagonal nut
6605001	Potentiometer nut	6880008	Handle
6605005	Strobe-adapter	6880012	Guide spacer
6605007	Coil spring	6880019	Mounting gauge
6605009	Engaging lever	6880077	Insulating spacer
6605012	Strobe cover	6883001	Mirror
6605013	Shielding cover	6883002	Cover
6605014	Shielding angle	6885007	Bearing turret
6605015	Transmission bar	7604001	Suspended chassis TD 104
6605016	Guide sleeve	7604014	Motor board TD 104
6605017	Rider	7605001	Suspended chassis TD 105
6605018	Rider nipple	7605002	Curve disk
6605019	Retaining spring	7605005	Auto-stop board
6605022	Base	7605006	Lift lever assembly
6605024	Insert piece	7605009	Rider TD 105
6605030	Support disk	7605010	Rider TD 104
6605031	Guide sleeve	7605011	Lift platform assembly
6605033	Contact leaf	7605012	Motor assembly
6605034	Knob	7605014	Motor board TD 105
6605035	Knob	7605015	Speed selector assembly

7605016	Stroboscope assembly LD 56-2
7605018	Suspension module
7605019	Hinge lever
7605020	Inner platter
7605023	Shielding cap
7874014	Threaded insert
7885001	Vertical bearing
7885003	Tone arm tube
7885004	Counterweight
8008061	Screw DIN 84 M 2,5 x 5
8008087	Screw DIN 84 M 3 x 5
8008088	Screw DIN 84 M 3 x 6
8008092	Screw DIN 84 M 3 x 14
8046004	Allen screw DIN 916 AM 3 x 8
8053166	Screw DIN 7985 M 3 x 10
8061201	Screw DIN 7981 B 2,2 x 4,5
8061206	Screw DIN 7981 B 2,9 x 6,5
8061207	Screw DIN 7981 B 2,9 x 9,5
8061208	Screw DIN 7981 B 2,9 x 13
8061210	Screw DIN 7981 B 2,9 x 19
8074207	Screw DIN 7982 B 2,9 x 9,5
8500002	Washer DIN 471 4 x 0,4
8501053	Washer DIN 125 A 2,2
8501057	Washer DIN 125 A 3,2
8501058	Washer DIN 125 A 3,7
8501061	Washer DIN 125 A 6,4
8501707	Washer DIN 125 A 3,2
8501709	Washer DIN 125 A 4,2
8504010	Spring washer DIN 137 A 4
8506022	Toothed washer DIN 6797 A 2,7
8507003	Clip washer DIN 6799 1,5
8507005	Clip washer DIN 6799 2,3
8507006	Clip washer DIN 6799 3,2
8508127	Washer DIN 9021 B 3,2
8508203	Washer DIN 9021 A 3,2
8598243	Spring washer
8604026	Nut DIN 562 M 3
8604028	Nut DIN 562 M 4
8605112	Nut DIN 934 M 4
9881000	TP 63 cartridge wand
9885000	TP 22 bearing assembly
5310017	Silicon AK 100 000
5511118	Packing carton
5511119	Corrugated panel
7605024	Styrofoam packing

105-0779-1

Printed in Germany